

# ROBO-8113VG2AR-Q170

6th Gen Intel® Core™ i5/i7 processor based PICMG® 1.3 SHB with DDR4 SDRAM, HDMI, DVI-I, Dual GbE LAN, Audio, USB

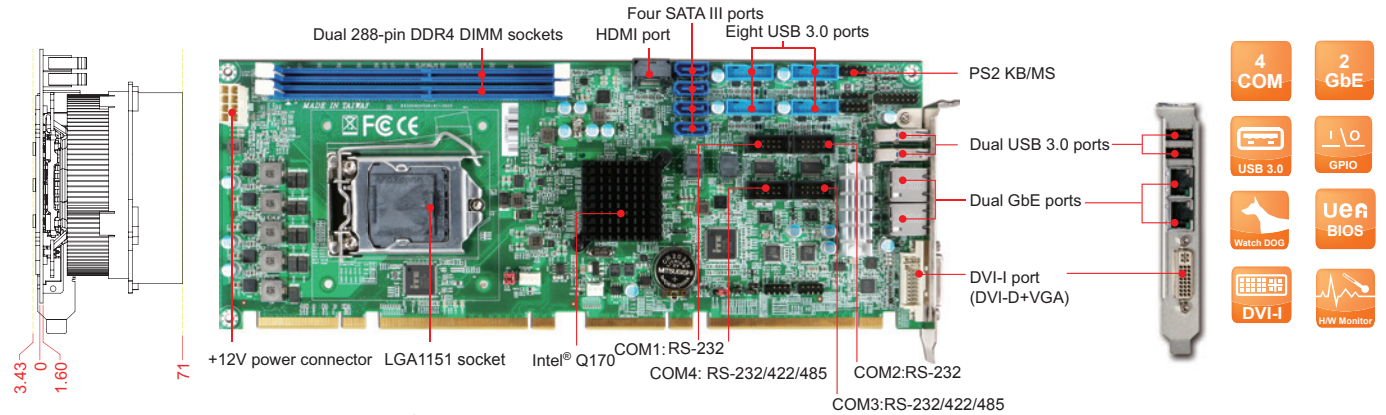

ROBO-8113VG2AR-Q170 is based on Intel® desktop processors and Q170 chipset. Built with flexible PCI Express configuration, ROBO-8113VG2AR-Q170 is suitable for medical, industrial automation, and digital signage applications.

## FEATURES

- 6th Gen Intel® Core™ i5 and i7 processors
- DDR4 2133/1866 MHz memory, 2x 288-pin DIMM socket, up to 32 GB
- Triple independent display by DVI-D, HDMI, and VGA
- Dual Gigabit Ethernet
- PCIe 3.0, USB 3.0, SATA III ports

## ORDERING GUIDE

ROBO-8113VG2AR-Q170	PICMG® 1.3 full-size SHB based on 6th Gen Intel® Core™ i5/i7 LGA1151 processor and Intel® Q170 chipset
---------------------	--

## OPTIONAL ITEMS

B6902980	PS/2 keyboard / mouse cable with bracket
B6903090	USB 3.0 cable with bracket
AB9-2066	PA-M1AU multimedia kit (Mic-in, Line-in, Line-out, 2x USB 2.0)

## PACKING LIST

	1x ROBO-8113 PICMG® 1.3 SHB
B8981980	1x SHB handling and installation notice
B8983660	1x driver CD
B6902932	1x SATA III cable
B6903350	1x DVI-D + VGA cable
B6902350	1x dual COM port cable with bracket

## General

Processor	Intel® Core™ i5/i7 processors up to 3.4 GHz (35~65W) in LGA1151 package Intel® Turbo Boost, Hyper-Threading, Virtualization, Thermal Monitoring, Trusted Execution, and SpeedStep Technology (depend on processor SKU)
Chipset	Intel® Q170
BIOS	AMI UEFI BIOS (SPI ROM)
Memory	Dual-channel (non-ECC) DDR4 2133/1866 MHz memory 2x 288-pin DIMM sockets, up to 32 GB
Storage Devices	4x SATA III ports 2x SATA III ports via backplane SW RAID 0, 1, 5, 10
Watchdog Timer	Programmable 0.5 to 254.5 seconds interval
Hardware Monitoring	System monitor (voltage, fan speed, and temperature)
Expansion Interface	From CPU: - 1x PCIe x16 or 2x PCIe x8 or 1x PCIe x8 + 2x PCIe x4 (Gen3, by jumper setting) From chipset: - 1x PCIe x4 or 4x PCIe x1 (Gen3, by BIOS support)

## I/O Interface

Embedded Controller	ITE IT8528E
Audio	Intel® High Definition audio interface Realtek® ALC886-GR High Definition Audio 1x audio pin header (2.54 mm pitch)
Ethernet	2x Gigabit Ethernet (Intel® I219-LM and Intel® I210-AT) 2x RJ45 connectors with LED on rear bracket
Serial Port	LPC to COM port IC: Fintek F81216DG 2x RS-232 ports on pin header (2.54 mm pitch) 2x RS-232/422/485 on pin header (selectable by BIOS; 2.54 mm pitch)
USB	2x USB 3.0 on rear bracket 8x USB 3.0 on pin header (2.00 mm pitch) 2x USB 2.0 through backplane
Keyboard & Mouse	PS/2 keyboard & mouse on pin header (optional cable is required)
GPIO	8-bit
Other	TPM 2.0 (Infineon SLB 9665 TT.2.0)

## Display

Graphic Controller	Integrated Intel® HD graphics Supports DirectX 11/12, OpenGL 4.3/4.4, ES 2.0, OpenCL 2.x
Display Interface	Triple independent display by: 1x VGA (through DVI-I on rear bracket), resolution up to 1920 x 1200 @ 60Hz 1x DVI-D (through DVI-I on rear bracket), resolution up to 1920 x 1200 @ 60Hz 1x HDMI on internal connector, resolution up to 4096 x 2160 @ 24Hz

## Mechanical & Environmental

Dimension	338.5 x 126.4 mm (13.3" x 5.0")
Power Supply	Typical: +12V, +5V Support ATX mode
Environment	Operating temperature: 0°C to 60°C Storage temperature: -20°C to 80°C Relative humidity: 5~90%, non-condensing
MTBF	Over 100,000 hours at 40°C

